

# WELCOME



This pocket grading guide sets out the grading requirements for roofing battens that have not been pre-graded or there is a doubt over the grade.

All defects should be cut out and any batten less than 1.2 metres long discarded. (or sufficient to span at least 3 supports). All joints should be square cut and butted centrally on the supports. For trussed rafter roofs where the batten gauge is greater than 200mm there should be no more than 1 joint in any 4 consecutive battens on the same support and 1 in 3 when the gauge is less than 200mm. Consult BS8000:part 6:1990 for further information. Battens should be nailed to each rafter or support.

All **JBRED** battens have been pre-graded and require no further grading.

For more information on JBRED, or any other John Brash products please see contact details on back cover.

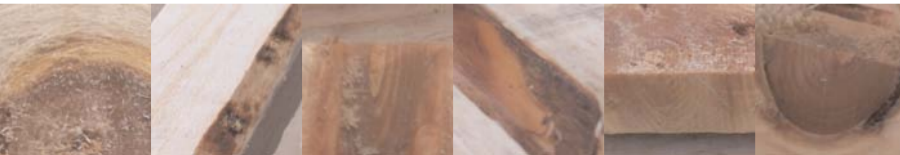

**KNOT SIZES** - For knot sizes, the sum of dimensions K1 and K2 encompassing a knot should not exceed the actual width of the batten.

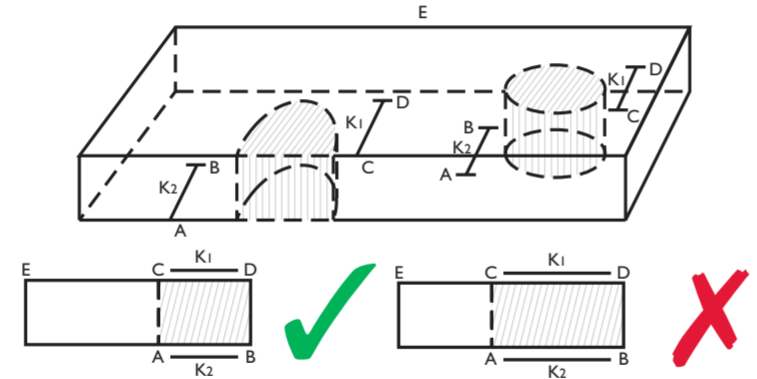

K1 (C-D) + K2 (A-B) must not exceed the width (D-E)  
 25 x 38 - K1+ K2 must be less than 38mm  
 25 x 50 - K1+ K2 must be less than 50mm

A knot appearing on both sides of the batten is not deemed to be a permissible defect if any part of the knot is less than 5mm from the face.

NOTE: Face is parallel to the slating or tiling. The width is the dimension of the face(s).

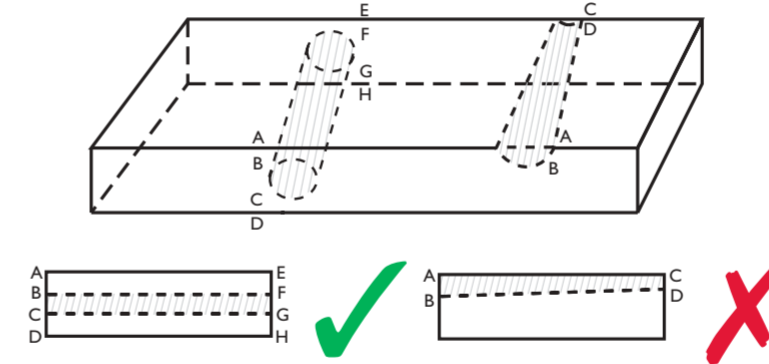

None of the measurements from A-B, C-D, E-F or G-H can be less than 5mm

**SLOPE OF GRAIN** - The deviation of the slope of grain from the longitudinal axis should not exceed 1 in 6 on either axis

NOTE A method and tool for measuring slope of grain is given in BS 4978.

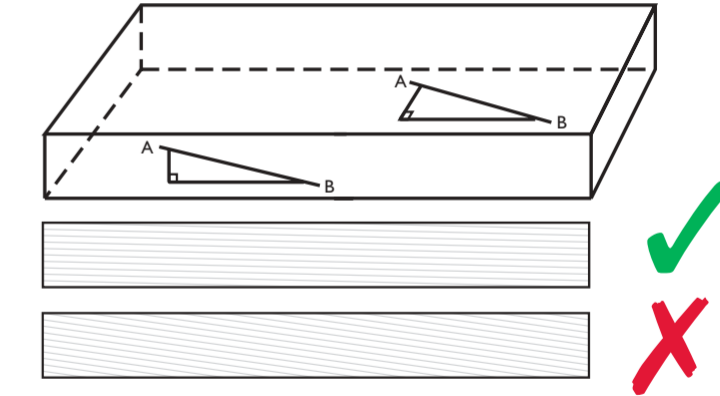

A-B must be no more than 1 in 6

**WANE** - Wane is permitted on one arris and should not exceed one-third of the dimension of each of the faces on which it occurs.

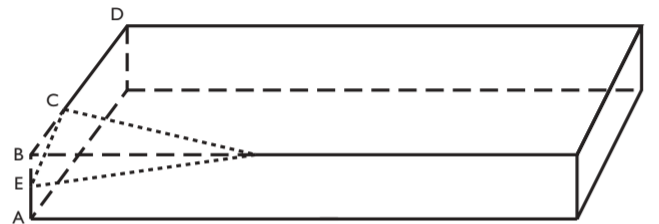

B-C must not exceed  $1/3$  B-D, B-E must not exceed  $1/3$  B-A  
 For 25 x 38 B-C must be less than 12.66mm and B-E less than 8.33mm  
 For 25 x 50 B-C must be less than 16.66mm and B-E less than 8.33mm

**RATE OF GROWTH** - There should be an average of not less than four annual growth rings per 25mm measured at each end.



**FISSURES AND SPLITS** - End splits (through the piece) that occur before fixing should be trimmed off. End splits or splits at intermediate supports that occur due to nailing should be not greater than 150mm long. Fissures (not through the piece) should not exceed half the batten thickness nor exceed 300mm in length.



A-C can not be more than  $1/2$  A-B  
 For 25 x 38 or 25 x 50 A-B must be less than 12.5mm

**DIMENSION TOLERANCES** - Battens should meet the following tolerances

Width +/- 3mm  
 Thickness +3mm/-0mm  
 When measured at a reference moisture content of 20%

**DECAY AND INSECT ATTACK** - Battens and counter-battens should be free from rot and live insect attack.

**SAP STAIN** - Sap stain such as 'blue stain' is not deemed to be a structural defect and is therefore permitted.

**RESIN POCKETS** - Resin pockets on either face of a batten are permitted provided that no resin pocket exceeds 70mm in length, or 6mm in width, or one-third of the batten thickness. Resin pockets on either side of a batten are permitted provided that no resin pocket exceeds 70mm in length, or 6mm in width, or 12mm in depth.

**MOISTURE CONTENT** - The moisture content at the time of fixing should not exceed 22%.

NOTE: The dimensions of battens and counter-battens are based on measurement at 20% moisture content. As timber swells on wetting and shrinks on drying, dimensions measured at other moisture contents may be adjusted to the 20% values by allowing 1% change in cross-sectional dimensions for every 4% change in moisture content.

## WHY USE JOHN BRASH?



John Brash & Co is the UK leading manufacturer of roofing battens. We lead the way in setting standards for battens and were the first to introduce the graded and marked batten. We offer two options for roofing battens:

- JBRED** This is our 100% graded BS5534:2003 batten. It is highly distinctive with its red colouration. This meets all aspects of BS5534:2003 and is treated to BS8417:2003
- JBGREEN** This is our traditional batten. Graded and marked for final grade on site. It is pre graded to all aspects of BS5534:2003 and just needs final grading for knots and wane.

All other battens will probably need inspection for all aspects required in this guide.





JOHN BRASH & COMPANY LTD  
THE OLD SHIPYARD GAINSBOROUGH LINCOLNSHIRE DN21 1NG  
MAIN NO. 01427 613858 | SALES NO. 01427 675555 | FACSIMILIE 01427 810218  
EMAIL INFO@JOHNBRASH.CO.UK | WEBSITE WWW.JOHNBRASH.CO.UK

< back cover - need to provide a short run version without bre logo



JOHN BRASH & COMPANY LTD  
THE OLD SHIPYARD GAINSBOROUGH LINCOLNSHIRE DN21 1NG  
MAIN NO. 01427 613858 | SALES NO. 01427 675555 | FACSIMILIE 01427 810218  
EMAIL INFO@JOHNBRASH.CO.UK | WEBSITE WWW.JOHNBRASH.CO.UK

< back cover - bre logo should be sorted in march then we can print properly